



BRIKA

B-B4T-V

ROBUST DESIGN
HIGH QUALITY STAINLESS STEEL

ELECTRIC COMBI OVEN BISTROT 4T VISION



Automatic preheating & delayed start programming

Multi-timer function for multiple & mixed cooking

Fan inversion, speed control and motor break

5 Fan speeds and semi-static cooking

Temperature up to 270°C / 520°F

Pre-loaded & online cookbook + USB

Custom preset programs mode

9 Cooking modes

Accommodates 18" x 26" bunpans & smaller

BakeDRY automatic chimney opening

BakeSTEAM steam control in percentages

BakeCLEAN automatic washing system

BakePOINT multipoint core probe

OPTIONS

- BakeHIN vacuum core probe
- BakeNET network connection
- Left hinge door
- Pasteurization kit

Dimensions (wxdxh) 33^{1/2}" x 38" x 26^{1/2}"

Cooking Area (wxd) 18" x 26"

Tray distance 3" **Rack Guides** 4



B-B4T-V

DELIVERY

Box dimensions (w×d×h)

36^{1/4"} × 39^{3/8"} × 25^{5/8"}

Weight

net: 150 lbs

ship: 187 lbs

Power 8 KW

208V / 1PH - 36.1 AMP

208V / 3PH - 20.9 AMP

240V / 1PH - 31.3 AMP

240V / 3PH - 18.1 AMP

TOP VIEW

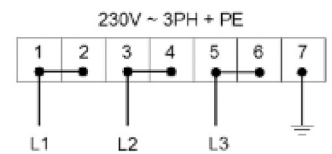
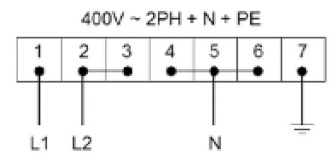
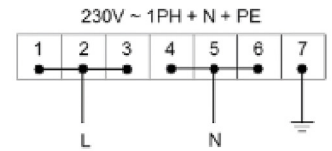
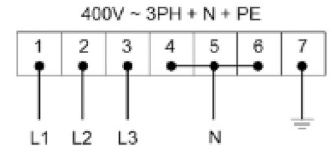
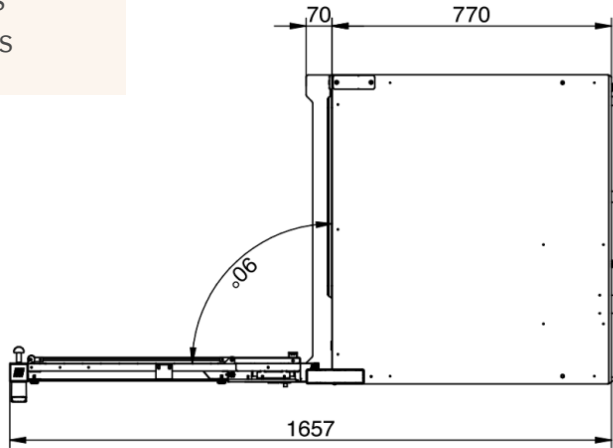

SIDE VIEW

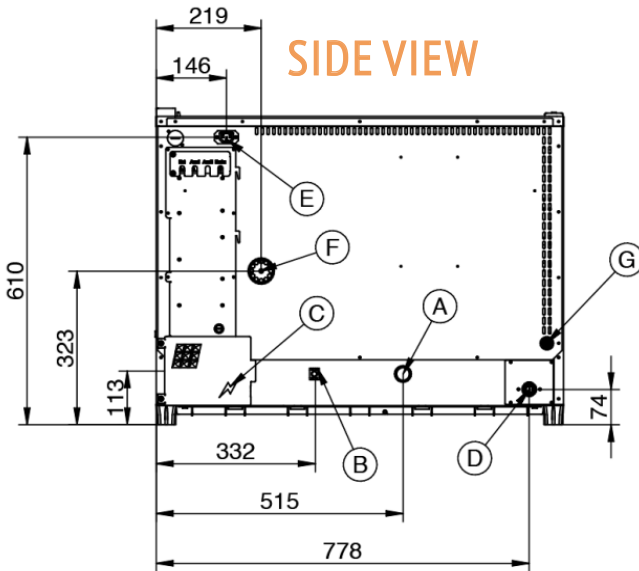

FRONT VIEW

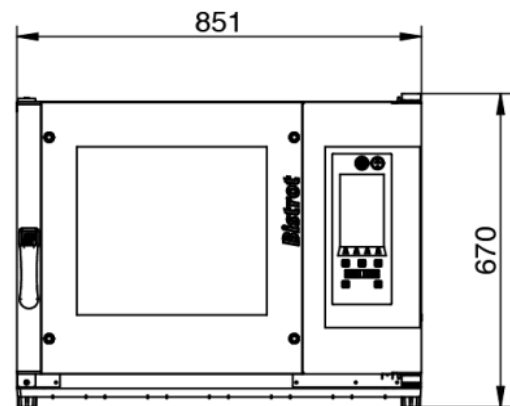

ASSEMBLY/SUPPORT



MORE PRODUCTS



SAFETY

Keep combustibles a minimum of 17" away from the equipment. Keep a clearance of 4" at the rear.

 We're on social media! 

1.800.567.3620 | WWW.BRIKA.COM